

INSTALLATION INSTRUCTIONS

for Neutral Drain Pack (60 Hz)



⚠ WARNING

Electrical Shock Hazard

- Disconnect power before servicing.
- Replace all panels before operating.
- Failure to do so can result in death or electrical shock.

NOTE: The neutral drain pack cannot be used in direct-into-spin gearcases.

Retainer Rack/Shoulder Pawl Stud Determination Procedure

1. Examine the main drive gear to see if an "X" is marked into it. See Figure 1.

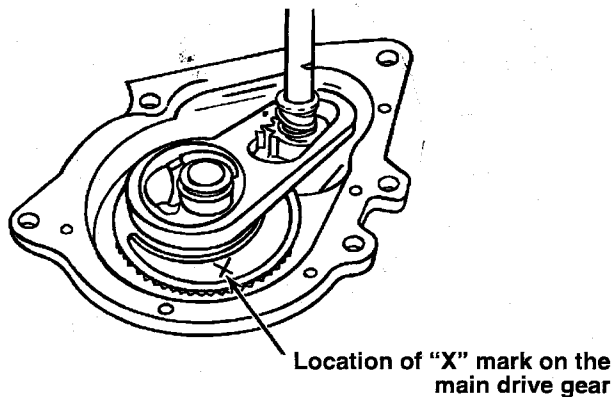

Figure 1

2. If the answer to number 1 is yes, then use new retainer rack and large pawl stud with blue Loctite patch. See Figure 2.

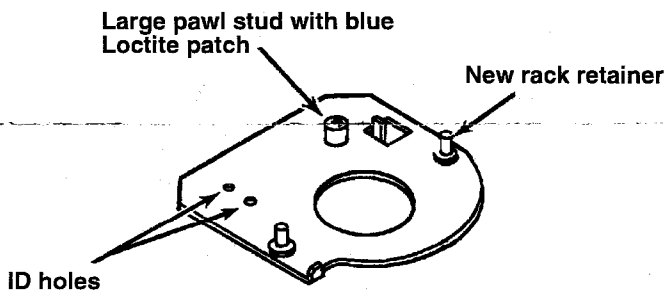

Figure 2

3. If the answer to number 1 is no, then use old retainer rack and small pawl stud (Refer to Figure 3, Rack retainer).
4. After determining which rack retainer and pawl stud should be used, follow installation procedure.

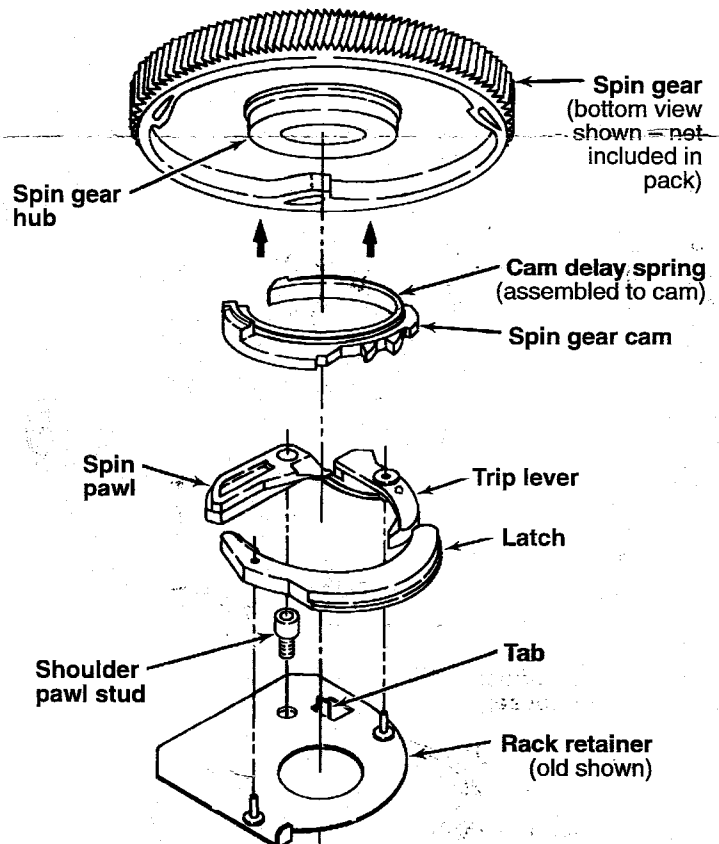

Figure 3

Installation Procedure

1. Install spin gear with cam delay spring to spin gear hub in direction shown.
2. Install rack retainer using the shoulder pawl stud. (Use rack-stud determination procedure to find out which rack retainer and pawl stud should be used.)
3. Install trip lever. The spring of the trip lever **MUST** rest against the tab on the rack retainer, and trip lever will snap into place.
4. Install spin pawl and latch as shown.